

UR12e

Technical specification

Our most versatile robot, the UR12e delivers an impressive payload of 12.5 kg and 1300 mm reach, making it ideal for a wide range of applications.

Today, more than 100,000 UR collaborative industrial robots have been delivered to customers across industries and around the world. The e-Series of cobots brings incredible flexibility and unparalleled ease of use to your application.

Updated April 2025.

Copyright © 2025 by Universal Robots A/S. All rights reserved.

UR12e

Specification

Payload	12.5 kg (27.5 lbs)
Reach	1300 mm (51.2 in)
Degrees of freedom	6 rotating joints
Programming	12-inch touchscreen with PolyScope graphical user interface
Power consumption (average)	
Maximum power	615 W
Moderate operating settings	350 W
Operating temperature range	Ambient temperature: 0-50°C (32-122°F)
Safety functions	17 configurable safety functions
In compliance with	EN ISO 13849-1 (PLd Category 3) and EN ISO 10218-1

Performance

Force sensing, tool flange/torque sensor	Force, x-y-z	Torque, x-y-z
Range	± 100.0 N	± 10.0 Nm
Precision	± 5.0 N	± 0.2 Nm
Accuracy	± 5.5 N	± 0.5 Nm

Movement

Max TCP speed	4 m/s
Pose Repeatability per ISO 9283	± 0.05 mm

Axis movement	Working range	Maximum speed
Base	± 360°	± 120°/s
Shoulder	± 360°	± 120°/s
Elbow	± 360°	± 180°/s
Wrist 1	± 360°	± 180°/s
Wrist 2	± 360°	± 180°/s
Wrist 3	± 360°	± 180°/s

Features

IP classification	IP54
Noise	< 65 dB(A)
Robot mounting	Any orientation
I/O Ports	
Digital In	2
Digital Out	2
Analog In	2
Tool I/O power supply voltage	12/24 V
Tool I/O power supply	2 A (Dual pin) 1 A (Single pin)

Physical

Footprint	Ø190 mm
Materials	Aluminum, plastic, steel
Tool flange interface	M8 8-pin female, EN ISO-9409-1-50-4-M6
Connector type	M8 8-pin female
Cable length (robot arm)	6 m (236 in)
Weight including cable	33.5 kg (73.9 lbs)
Humidity	≤ 90% RH (non-condensing)

Contact

Universal Robots A/S
Energivej 51
5260 Odense
Denmark

+45 89 93 89 89
sales@universal-robots.com
universal-robots.com

Teach Pendant

Features

IP classification	IP54
Humidity	≤ 90% RH (non-condensing)
Display resolution	1280 x 800 pixels

Physical

Materials	Plastic
Teach Pendant size (W x H x D)	300 mm x 231 mm x 50 mm (11.8 in x 9.1 in x 1.97 in)
Weight	1.6 kg (3.5 lbs) including 1 m of Teach Pendant cable
Cable length	4.5 m (177.17 in)

Control Box

Features

IP Classification	IP44
Operating temperature range	Ambient temperature: 0-50°C (32-122°F)
Humidity	≤ 90% RH (non-condensing)

I/O Ports

Digital In	16
Digital Out	16
Analog In	2
Analog Out	2
Quadrature Digital Inputs	4
I/O Power Supply	24V, 2A
Industrial Protocols	Modbus-TCP (Client/Sever) Ethernet/IP Adapter PROFINET device/PROFIsafe ROS/ROS2

Hardware Interfaces

Hardware Interfaces	Ethernet 1 Gb/s USB 2.0, USB 3.0 Mini DisplayPort Injection Moulding Machine Interface (SPI AN-146 & Euromap-67)
---------------------	---

Power Source

Power Source	100-240 VAC, 47-440 Hz
--------------	------------------------

Physical

Control Box Size (W x H x D)	460 mm x 449 mm x 254 mm (18.2 in x 17.6 in x 10 in)
Weight	12 kg (26.5 lbs)
Materials	Powder coated steel

The control box is also available in an OEM version

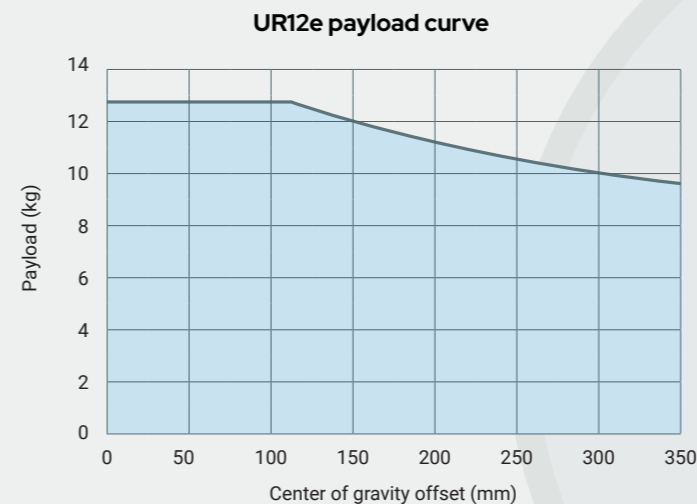

Interface for UR12e base flange

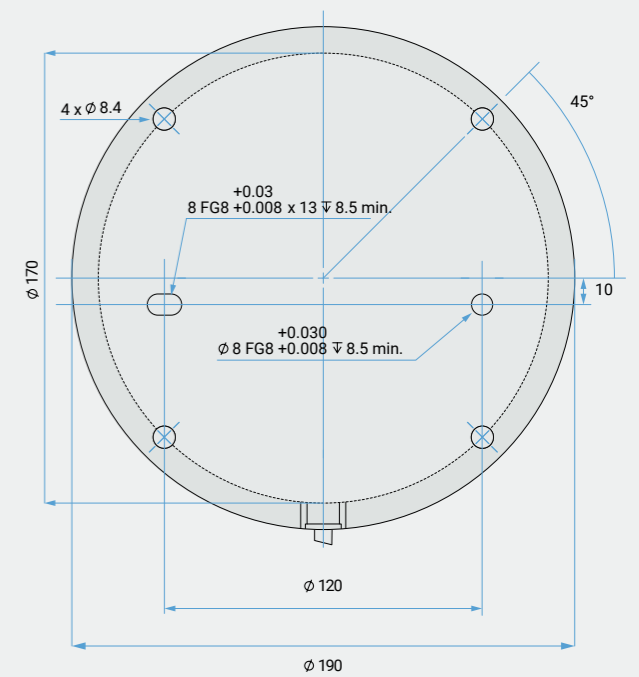

Tool flange for UR12e

