



# UR15

## Technical specification

**UR15. Sharp. Compact. Outsized performance at arm's reach.**

The UR15 is the most lightweight member of the UR Series surpassing the expectations for the most sought-after size representing a sweet spot within the collaborative robot market offering speed and dependability that easily fits in a variety of environments.

Updated May 2025.

Copyright © 2025 by Universal Robots A/S. All rights reserved.

## UR15

### General specification

Payload	15 kg (33.1 lbs) 17.5 kg (38.58 lbs) with boundary conditions according to manual
Reach	1300 mm (51.18 in)
Degrees of freedom	6 rotating joints
Programming	12 inch touchscreen with PolyScope graphical user interface
<b>Power consumption (average)</b>	
Maximum power	550 W
Moderate operating settings	350 W
Operating temperature range	Ambient temperature: 0-50°C (32-122°F)
Safety functions	17 configurable safety functions
In compliance with	EN ISO 13849-1 (PLd Category 3), EN ISO 10218-1 and UL 1740
Joint architecture	2-1-3

## UR15 robot arm

### Performance

Force sensing, tool flange/torque sensor	Force, x-y-z	Torque, x-y-z
Range	± 150.0 N	± 10.0 Nm
Precision	± 7.5 N	± 0.2 Nm
Accuracy	± 8.3 N	± 0.5 Nm

### Movement

Max TCP speed	5 m/s
Pose repeatability per ISO 9283	± 0.05 mm

Axis movement	Working range	Maximum speed
Base	± 360°	± 180°/s
Shoulder	± 360°	± 180°/s
Elbow	± 360°	± 240°/s
Wrist 1	± 360°	± 300°/s
Wrist 2	± 360°	± 300°/s
Wrist 3	± 360°	± 300°/s

### Features

IP Classification	IP65
Noise	< 67 dB(A)
Status identification	Light ring at robot base
Arm mounting	Any orientation
<b>I/O Ports at tool flange</b>	
Digital In	2
Digital Out	2
Analog In	2 or 1 RS-485
Power supply voltage	12/24 V
Power supply	2 A (Dual pin), 1 A (Single pin)

### Physical

Footprint	Ø204 mm
Materials	Aluminum, plastic, steel
Tool flange	ISO 9409-1-50-4-M6
Connector type	M8 8-pin female
Cable length (robot arm)	6 m (236 in)
Weight including cable	40.7 kg (89.73 lbs)
Humidity	≤ 90% RH (non-condensing)

## Contact

Universal Robots A/S  
Energivej 51  
5260 Odense  
Denmark

+45 89 93 89 89  
[sales@universal-robots.com](mailto:sales@universal-robots.com)  
[universal-robots.com](http://universal-robots.com)

## 3-Position Enabling Teach Pendant

### Features

IP classification	IP54
Humidity	≤ 90% RH (non-condensing)
Display resolution	1280 x 800 pixels

### Physical

Materials	Plastic
Teach pendant size (W x H x D)	300 mm x 231 mm x 50 mm (11.8 in x 9.1 in x 1.97 in)
Weight	1.8 kg (3.961 lbs) including 1 m of teach pendant cable
Cable length	4.5 m (177.17 in)

## Control Box

### Features

IP classification	IP44
Humidity	≤ 90% RH (non-condensing)
<b>I/O Ports</b>	
Digital In	16
Digital Out	16
Analog In	2
Analog Out	2
Quadrature digital inputs	4
I/O Power Supply	24V, 2A
Industrial protocols	Modbus TCP (Client/Server) Ethernet/IP Adapter PROFINET device, PROFIsafe ROS/ROS2
Hardware interfaces	Ethernet 1 Gb/s USB 2.0 USB 3.0 Mini DisplayPort Injection Moulding Machine Interface (SPI AN-146 & Euromap-67)*
Power Source	115/230 VAC, 50/60 Hz

\*Only valid for OEM version.

### Physical

Control Box Size (W x H x D)	460 mm x 449 mm x 254 mm (18.2 in x 17.6 in x 10 in)
Weight	12 kg (26.5 lbs)
Materials	Powder coated steel

The controlbox is also available in an OEM version.

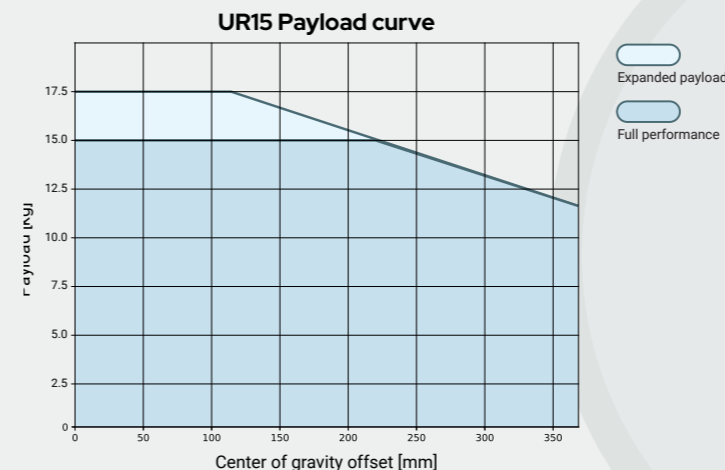

### Mounting hole pattern with pins for robot base

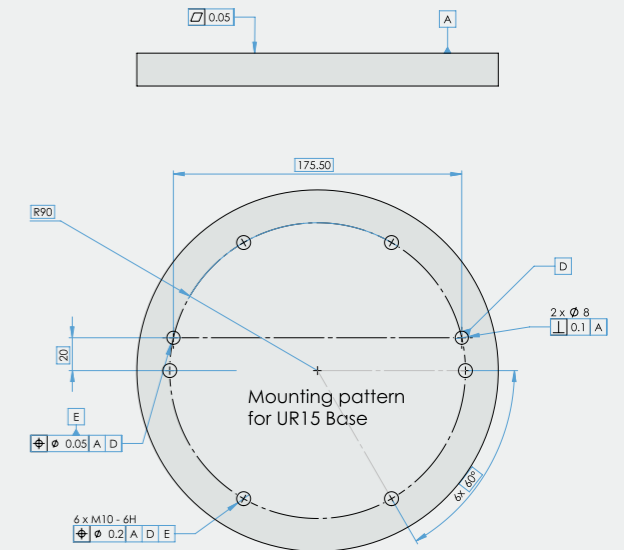

### Recommended hole pattern for robot base

